

- Journal bearing, oil & water-cooled CHRA
- Smallest Garrett® turbocharger available
- Excellent for motorcycles or other small displacement engines
- Internally wastegated turbine housing, complete with actuator

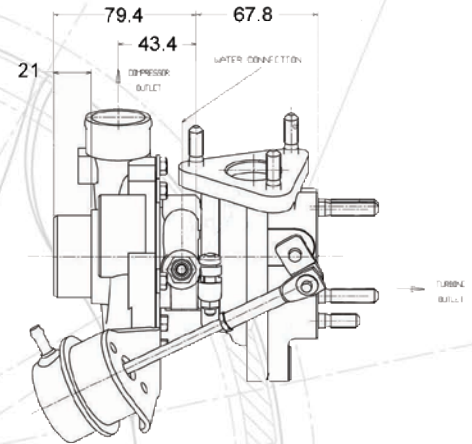

GT1241		COMPRESSOR				TURBINE		
Turbo PN	CHRA PN	Ind Whl Dia	Exd Whl Dia	Trim	A/R	Whl Dia	Trim	A/R
756068-1	757864-1	29.0mm	41.0mm	50	0.33	35.5mm	72	0.43

