

- Dual ball bearing, oil & water-cooled CHRA
- Internally wastegated turbine housing complete with actuator
- Turbine housing is cast from high-nickel "Ni-Resist" material (466541-4 only)
- Turbine wheel is cast from "Inconel" material for extreme applications (466541-4 only)
- OEM turbocharger on Nissan SR20DET engine
- Upgrade for GT2554R (471171-3), outline interchangeable except compressor inlet

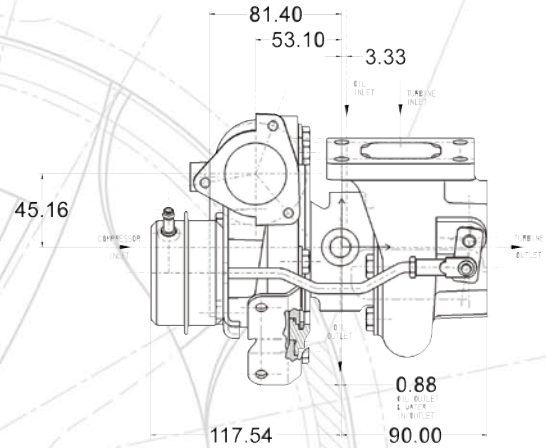

GT2560R		COMPRESSOR				TURBINE		
Turbo PN	CHRA PN	Ind Whl Dia	Exd Whl Dia	Trim	A/R	Whl Dia	Trim	A/R
466541-1	446179-12	46.5mm	60.1mm	60	0.60	53.0mm	62	0.64
466541-4	446179-38	46.5mm	60.1mm	60	0.60	53.0mm	62	0.64

