

- Dual ball bearing, oil & water-cooled CHRA
- Internally wastegated turbine housing complete with actuator
- Turbine housing has a unique "compact" 5-bolt outlet that is not interchangeable with traditional T25 5-bolt outlets
- Bolt-on upgrade for Nissan RB26DETT
- Turbine housing cast from "Ni-Resist"
- Turbine wheel is cast from "Inconel" material for extreme applications

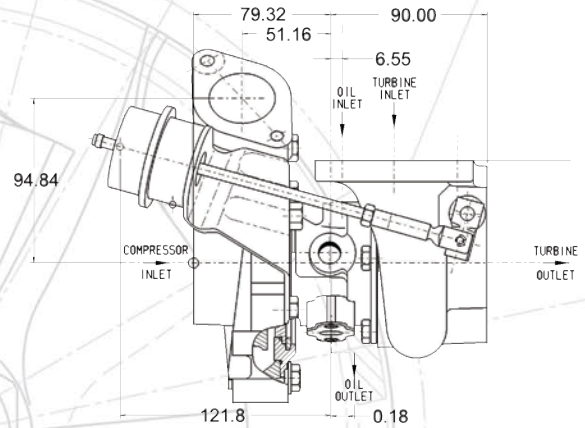

GT2860R		COMPRESSOR				TURBINE		
Turbo PN	CHRA PN	Ind Whl Dia	Exd Whl Dia	Trim	A/R	Whl Dia	Trim	A/R
707160-5	446179-51	47.2mm	60.1mm	62	0.60	53.9mm	76	0.64

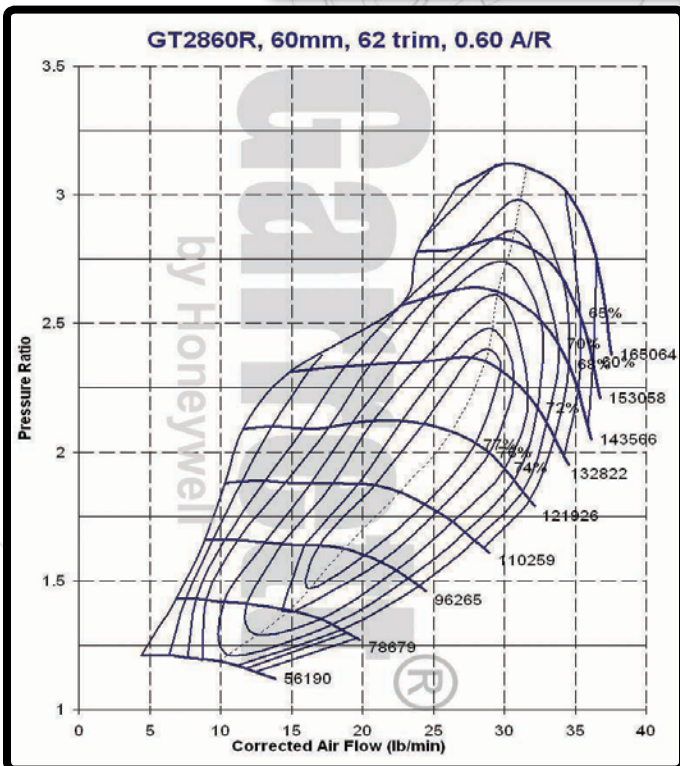

TURBINE HOUSING OPTIONS	
PN	A/R
430609-230*	0.64
430609-231*	0.86

\* Note: allows turbo to be outline interchangeable with other turbos using the traditional 5-bolt turbine housing (Diagram 85-11). Housing fits over turbine wheel but actuator/wastegate fitment may need to be adjusted

