

- Dual ball bearing, oil & water-cooled CHRA
- Internally wastegated turbine housing complete with actuator
- Turbine housing has a unique “compact” 5-bolt outlet that is not interchangeable with traditional T25 5-bolt outlets
- Turbine housing cast from high-nickel “Ni-Resist” material
- Turbine wheel is cast from “Inconel” material for extreme applications
- Bolt-on turbo for Nissan RB26DETT

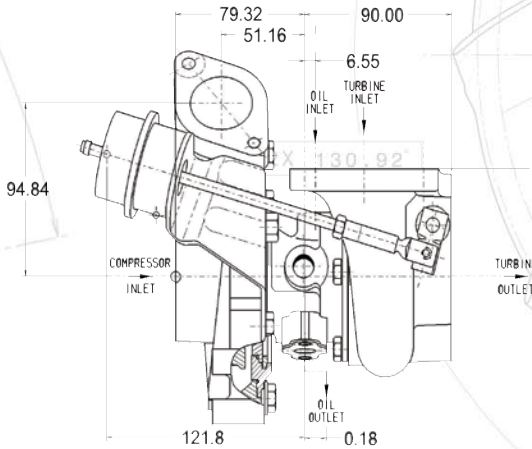

<b>DISPLACEMENT 1.8L - 3.0L</b>	<b>HORSEPOWER 150 - 310</b>	2000
		1900
		1800
		1700
		1600
		1500
		1400
		1300
		1200
		1100
		1000
		900
		800
		700
		600
		500
	400	
	300	
	200	
	100	
	0	

GT2860R		COMPRESSOR				TURBINE		
Turbo PN	CHRA PN	Ind Whl Dia	Exd Whl Dia	Trim	A/R	Whl Dia	Trim	A/R
707160-7	446179-54	44.6mm	60.1mm	55	0.42	53.9mm	62	0.64

