

2000	DISPLACEMENT 1.8L - 3.0L HORSEPOWER 280 - 475
1900	
1800	
1700	
1600	
1500	
1400	
1300	
1200	
1100	
1000	
900	
800	
700	
600	
500	
400	
300	
200	
100	
0	

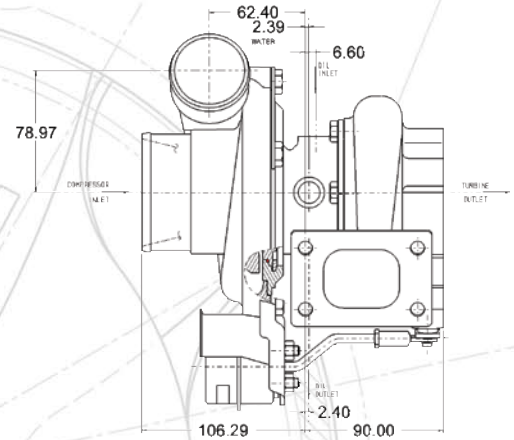

- Dual ball bearing, oil & water-cooled CHRA
- Internally wastegated turbine housing, complete with actuator
- Direct bolt-on upgrade turbocharger for GT2860RS (PN 739548-1)
- 743347-2 features a high boost actuator adjustable down to 12 psi
- 743347-4 features a low boost actuator adjustable down to 6 psi
- Turbine wheel is cast from "Inconel" material for extreme applications



GT2871R		COMPRESSOR				TURBINE		
Turbo PN	CHRA PN	Ind Whl Dia	Exd Whl Dia	Trim	A/R	Whl Dia	Trim	A/R
743347-2	446179-32	53.1mm	71.0mm	56	0.60	53.9mm	76	0.86
743347-4	446179-32	53.1mm	71.0mm	56	0.60	53.9mm	76	0.64

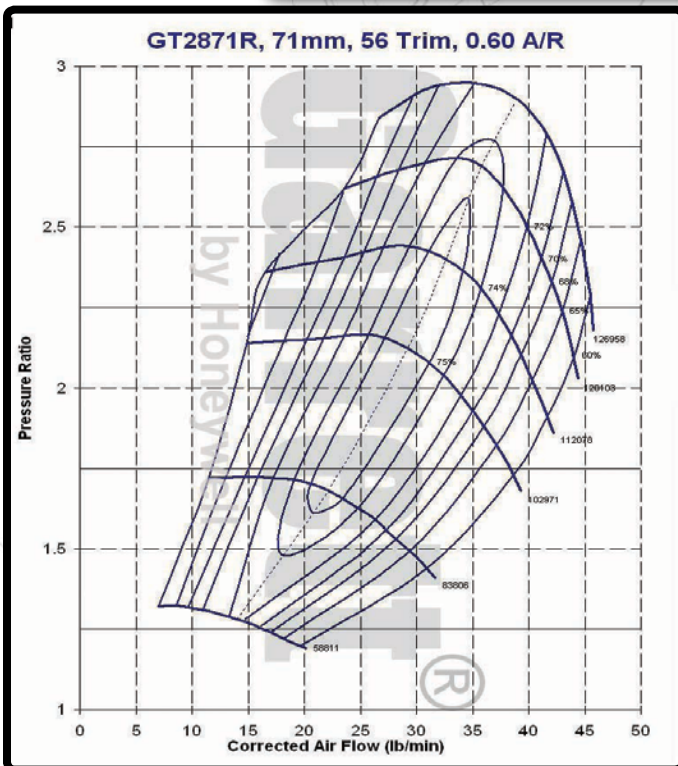

TURBINE HOUSING OPTIONS	
PN	A/R
430609-230	0.64
430609-231	0.86

