

S400SX3

500 - 1050 HP Turbo



FEATURES

- Twin hydrodynamic journal bearings
- Extended tip technology compressor wheel
- Twin scroll turbine housing
- Adjustable compressor and turbine housing orientation
- Standard turbine inlet and outlet allows for drop-in to existing turbocharged applications
- Compressor cover recirculation grooves



TURBO FRAME DIMENSIONS

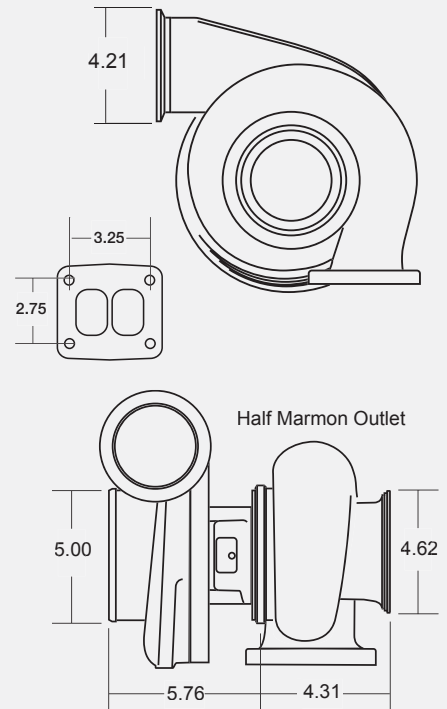

Turbo Part #	Comp. Wheel O.D. (in)	Comp Wheel O.D. (mm)	Comp Wheel Inducer Dia. (in)	Comp Wheel Inducer Dia. (mm)	Turbine Wheel O.D. (in)	Turbine Wheel O.D. (mm)	Turbine Wheel Exducer (in)	Turbine Wheel Exducer (mm)	Turbine Housing A/R	Cartridge Assembly	Service Kit (Standard)	Service Kit (360° thrust bearing)
177248	3.94	100.17	2.80	71.08	3.29	83.47	2.92	74.29	1.10	177249	318396	14007110000
177101	3.94	100.17	2.94	74.56	3.29	83.47	2.92	74.29	1.10	176807	318396	14007110000

COMPRESSOR MAP

Applicable to part number 177101

Comp. Wheel Inducer Dia. (mm) 74.56
Comp. Wheel Outer Dia. (mm) 100.17

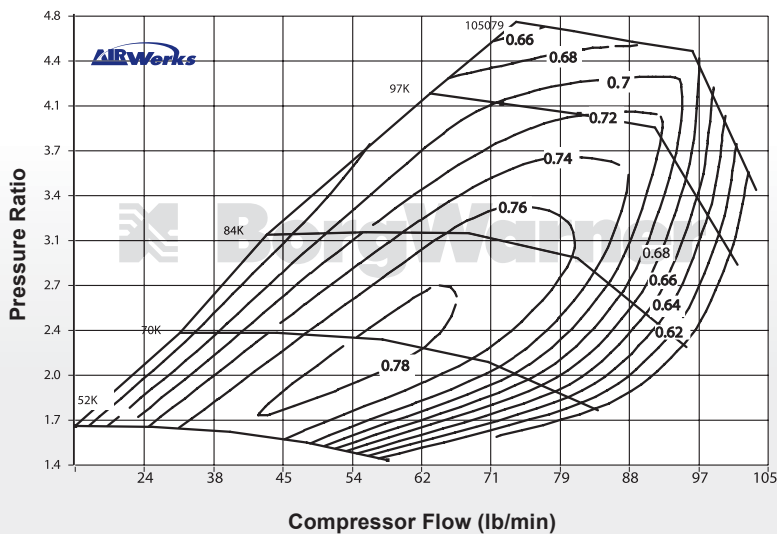

TURBINE HOUSING

Part #	A/R	Inlet Configuration	Notes
177102	0.90	Volute, Twin Flow	83mm Turbine Wheel
177103	1.00		
177104	1.10		
177105	1.25		