

- Dual ball bearing, oil & water-cooled CHRA
- Internally wastegated turbine housing, actuator NOT included
- Turbine wheel is cast from "Inconel" material for extreme applications

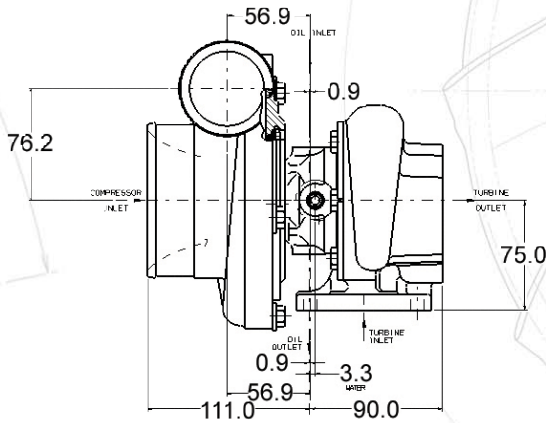

DISPLACEMENT 1.8L - 3.0L	HORSEPOWER 280 - 480	2000
		1900
		1800
		1700
		1600
		1500
		1400
		1300
		1200
		1100
		1000
		900
		800
		700
		600
		500
		400
	300	
	200	
	100	
	0	

GT2876R		COMPRESSOR				TURBINE		
Turbo PN	CHRA PN	Ind Whl Dia	Exd Whl Dia	Trim	A/R	Whl Dia	Trim	A/R
705330-1	446179-18	52.8mm	76.1mm	48	0.70	53.9mm	76	0.64
705330-2	446179-18	52.8mm	76.1mm	48	0.70	53.9mm	76	0.86

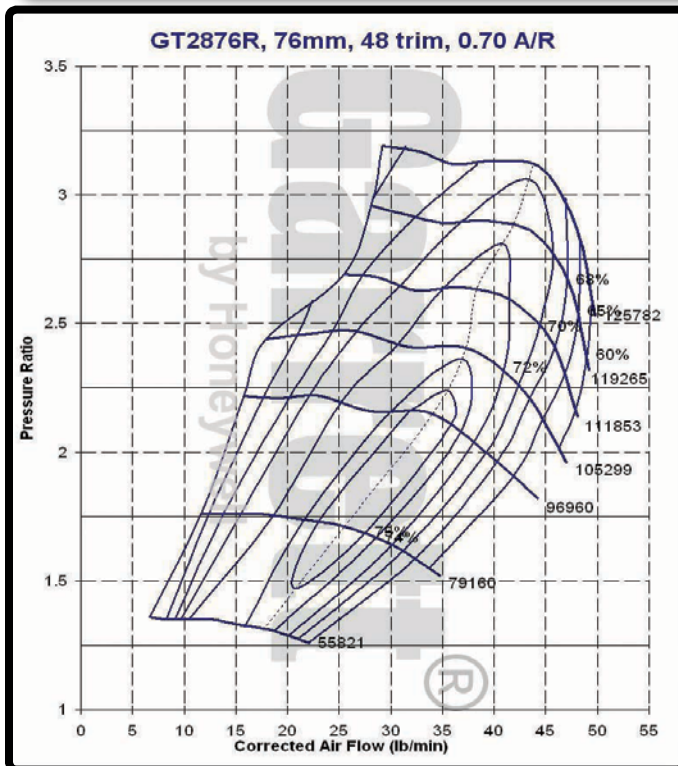

TURBINE HOUSING OPTIONS

PN	A/R
430609-230	0.64
430609-231	0.86

