

- Dual ball bearing, oil & water-cooled CHRA
- Internally wastegated turbine housing, actuator NOT included
- Wastegated version of the GT3071R uses specifically-modified GT30 turbine wheels for use in the T25-style turbine housing
- Turbine housing flanges are outline interchangeable with GT2554R (471171-3), GT2560R (466541-1) & GT2860RS (739548-1)
- Turbine wheel is cast from "Inconel" material for extreme applications

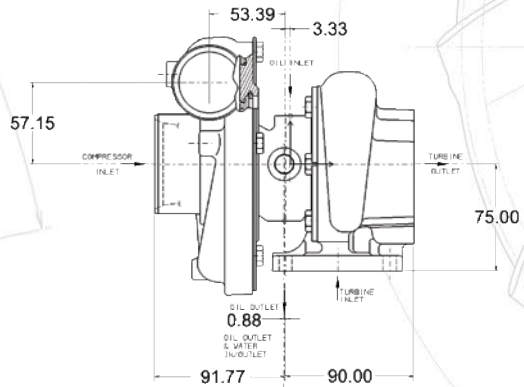

**DISPLACEMENT 1.8L - 3.0L**

**HORSEPOWER 280 - 480**

2000
1900
1800
1700
1600
1500
1400
1300
1200
1100
1000
900
800
700
600
500
400
300
200
100
0

GT3071R		COMPRESSOR				TURBINE		
Turbo PN	CHRA PN	Ind Whl Dia	Exd Whl Dia	Trim	A/R	Whl Dia	Trim	A/R
700382-3	700177-3	53.1mm	71.0mm	56	0.50	56.5mm	84	0.64
700382-20	700177-4	53.1mm	71.0mm	56	0.50	56.5mm	90	0.86

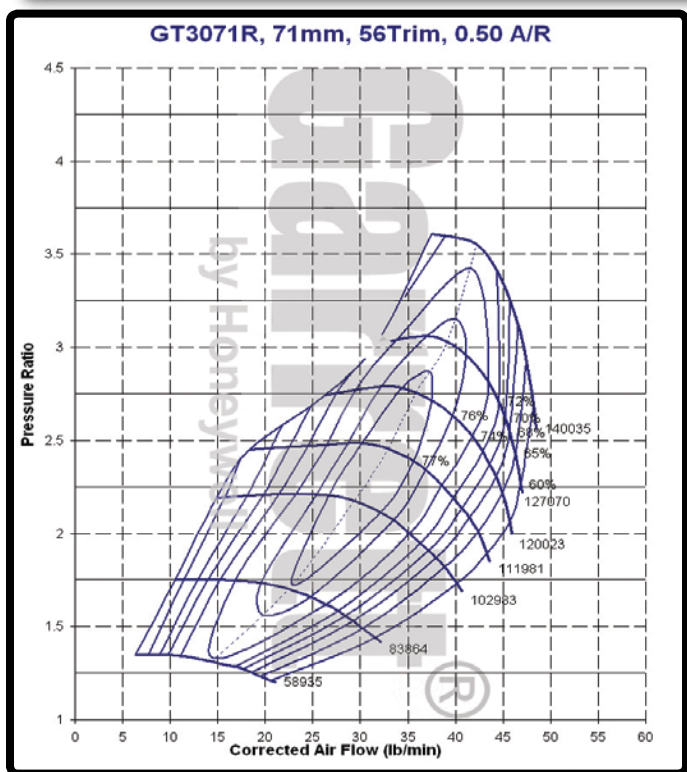

**COMPRESSOR HOUSING OPTIONS**

PN	Inlet Dia	Outlet Dia	A/R
756021-1*	2.75" Hose	2.00" Hose	0.50
756021-2+	4.00" Hose	2.00" Hose	0.50

\*Note: allows 700382-20 to use 2.75" hose inlet instead of 4.00"  
 +Note: allows 700382-3 to use 4.00" hose inlet instead of 2.75"

**Dimension Note: Compressor Inlet**  
 700382-3: flange 82-26 ; 756021-1: flange 82-26  
 700382-20: flange 82-34; 756021-2: flange 82-34

