

- Forged, fully-machined compressor wheel featuring next generation aerodynamics
- Dual ball bearing, oil & water-cooled CHRA
- Free float, non-wastegated turbine housing
- Ported shroud compressor housing to increase surge resistance
- Outline interchangeable with GT3071R
- GTX3071R is sold without turbine housing, includes CHRA & compressor housing. Turbine housing kits are available

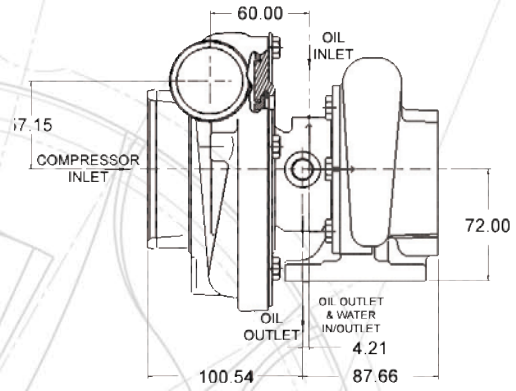

GTX3071R		COMPRESSOR				TURBINE		
Turbo PN	CHRA PN	Ind Whl Dia	Exd Whl Dia	Trim	A/R	Whl Dia	Trim	A/R
803712-1	700177-46	54.1mm	71.4mm	58	0.60	60.0mm	84	-

TURBINE HOUSING OPTIONS

PN	A/R	Inlet	Outlet
740902-1*	1.06	T3	4 Bolt
740902-2*	0.82	T3	4 Bolt
740902-3*	0.63	T3	4 Bolt
740902-7 ⁺	1.06	T3	V Band
740902-8 ⁺	0.82	T3	V Band
740902-9 ⁺	0.63	T3	V Band
740902-13 [^]	1.06	T4	V Band
740902-14 [^]	0.82	T4	V Band
740902-15 [^]	0.63	T4	V Band

GTX

Dimension Note: Turbine Housing Options
 * Note: Inlet flange: 83-04; Outlet flange: 85-07
⁺ Note: Inlet flange: 83-04; Outlet flange: 86-13
[^] Note: Inlet flange: 83-10; Outlet flange: 86-13

